

Inhalt
Contents
Contenu

Inhoud
Contenido
Conteúdo



Einzelteilübersicht / Spare parts list / Liste des pièces détachées / Onderdelenoverzicht / Lista da peças / Resumo de peça individual 2

Montagehilfen und Hinweise / Assembly aids and instructions / Aides de montage et instructions / Montagehulpmiddelen en aanwijzingen / Ayudas de montaje e instrucciones / Montagens e indicações 3

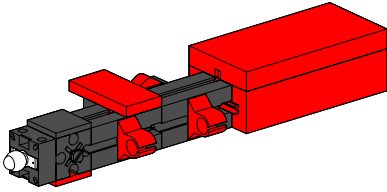

Taschenlampe / Torch / Lampe de poche / Zaklamp / Linterna / Lâmpada de mão 5

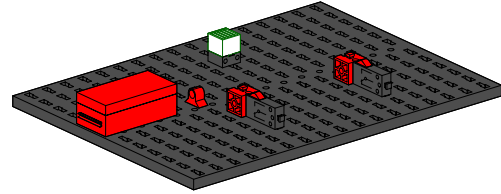

UND-/ ODER-Schaltung / AND-OR circuit / Circuit ET/OU / EN/OF-schakeling / Circuito Y/O / Conexão E/OU 11

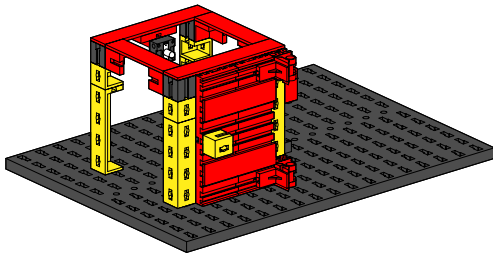

Kühlschrankbeleuchtung / Refrigerator with interior lighting / Réfrigérateur avec éclairage intérieur / Koelkast met binnenverlichting / Frigorífico con iluminación interior / Frigorífico com iluminação interior 6

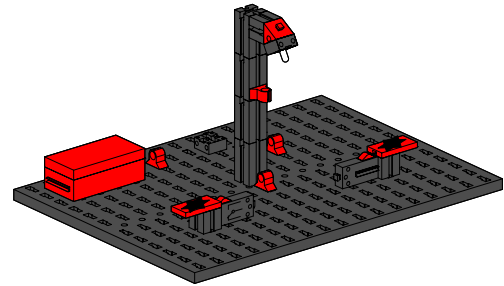

Treppenhausbeleuchtung / Staircase lighting / Éclairage de cage d'escalier / Trappenhuisverlichting / Iluminación de escalera / Iluminação do vão das escadas 12

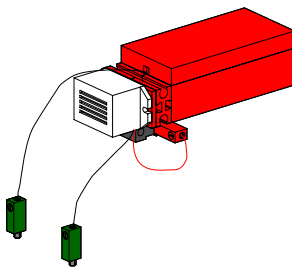

Durchgangsprüfer / Continuity tester / Appareil de contrôle de continuité/ Doorgangstester / Probador de continuidad / Verificador de continuidade 9

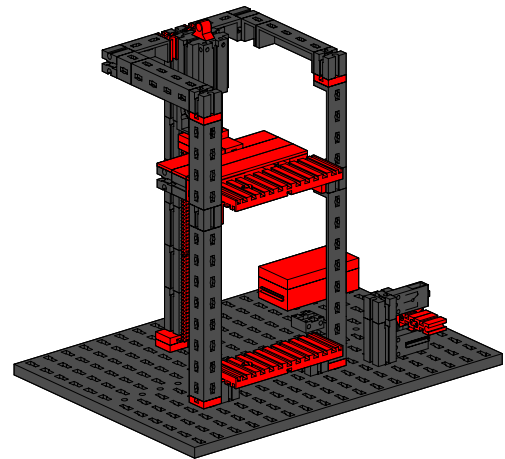

Aufzug / Elevator / Ascenseur / Lift / Ascensor / Elevador 14

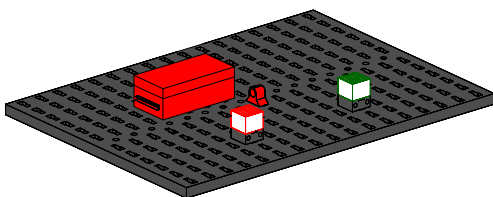

Reihen- und Parallelschaltung / Series and parallel connection / Circuit en série et en parallèle / Serie- en parallelschakeling / Conexión en serie y en paralelo / Conexão em série e paralela 10

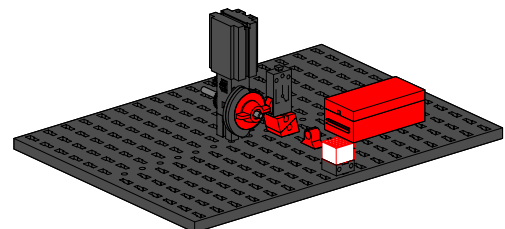

Einfaches Blinklicht / Simple flash light / Feu clignotant simple Eenvoudig knipperlicht / Luz intermitente sencilla / Lâmpada intermitente 19

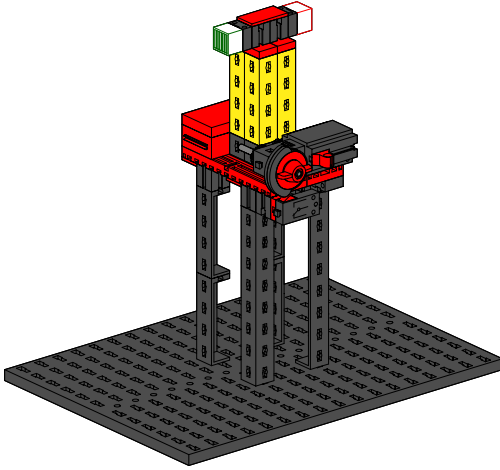

Turm mit Warnblinklicht / Tower with blinking warning light /
Tour avec feux de détresse / Toren met knipperlicht / Columna
con luz de aviso de emergencia / Torre com luz de aviso

20

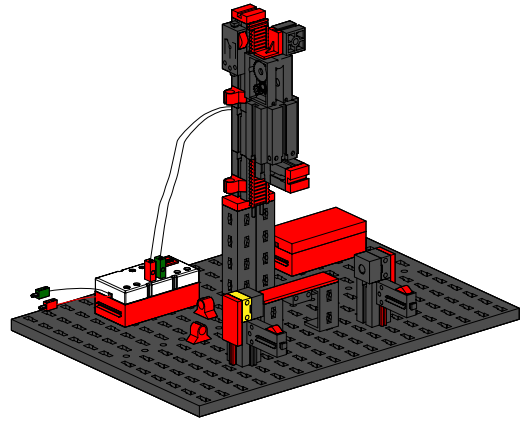

Stanzmaschine / Punching machine / Poinçonneuse /
Stansmaschine / Punzonadora / Máquina de puncionar

34

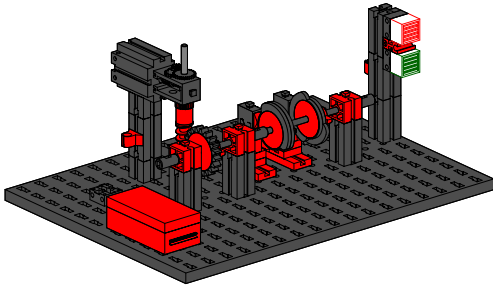

Ampelsteuerung / Traffic light control / Commande des feux de
signalisation / Regeling van een verkeerslicht / Mando del semáforo /
Comando de semáforo

24

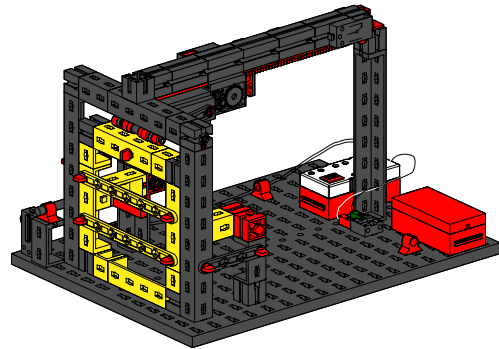

Garagentor / Garage door / Porte de garage / Garagedeur /
Puerta del garaje / Portão da garagem

38

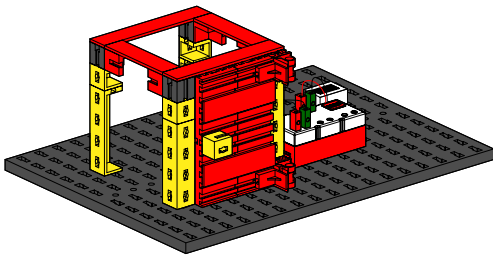

Alarmanlage / Alarm system / Dispositif d'alarme /
Alarminstallatie / Instalación de alarma / Sistema de alarma

28

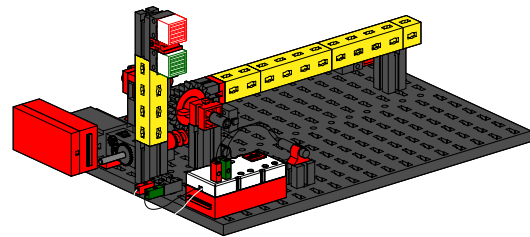

Parkhausschranke / Barrier of a public garage / Barrière de parking /
Slagboom aan de parkeergarage / Barrera del aparcamiento /
Barreiras do silo-auto

44

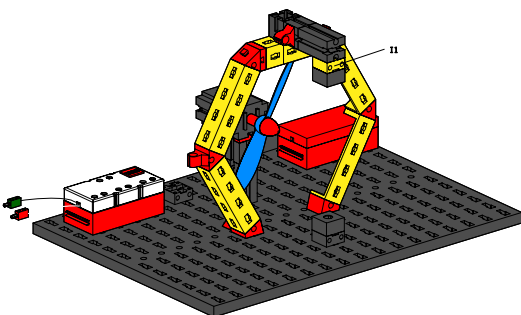

Händetrockner / Hand dryer / Sèche-mains /
Handendroger / Secamanos / Secador de mãos

31

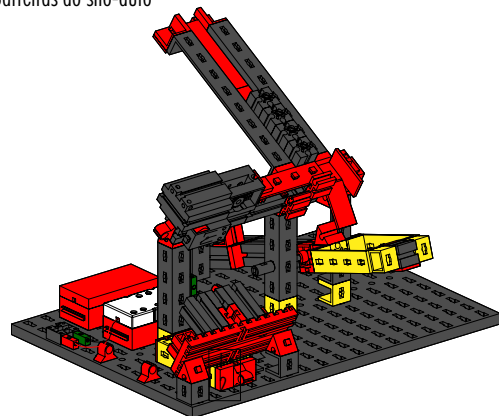

Bausteinspender / Brick dispenser / Distributeur d'éléments de
construction / Bouwsteenautomaat / Dispensador de elementos /
Distribuidor do componente

48

Einzelteilübersicht
Spare parts list
Liste des pièces détachées

Onderdelenoverzicht
Lista da piezas
Resumo de peça individual



	31 010 4 x		31 982 4 x		35 066 1 x		36 559 1 x		37 858 1 x
	31 011 3 x		32 064 4 x		35 073 3 x		36 819 1 x		37 869 2 x
	31 016 1 x		32 233 1 x		35 076 3 x		36 913 4 x		37 875 1 x
	31 021 1 x		32 263 1 x		35 079 1 x		36 920 4 x		38 216 4 x
	31 033 1 x		32 293 1 x		35 084 1 x		36 921 4 x		38 240 4 x
	31 058 3 x		32 330 2 x		35 087 1 x		36 950 4 x		38 241 4 x
	31 060 5 x		32 850 1 x		35 969 8 x		37 034 1 x		38 242 1 x
	31 061 2 x		32 859 2 x		36 119 1 x		37 237 4 x		38 245 2 x
	31 063 1 x		32 870 2 x		36 120 1 x		37 238 2 x		38 246 2 x
	31 078 1 x		32 879 11 x		36 134 1 x		37 272 1 x		38 423 4 x
	31 336 22 x		32 881 10 x		36 293 3 x		37 351 3 x		38 428 5 x
	31 337 22 x		32 882 4 x		36 297 4 x		37 468 4 x		38 464 4 x
	31 360 1 x		32 958 1 x		36 299 2 x		37 636 1 x		38 531 2 x
	31 426 2 x		32 985 1 x		36 323 11 x		37 679 4 x		108 227 1 x
	31 436 3 x		35 031 3 x		36 334 2 x		37 681 1 x		108278 1 x
	31 848 2 x		35 049 2 x		36 443 1 x		37 727 4 x		
	31 915 1 x		35 053 5 x		36 532 2 x		37 783 3 x		

