

**Inhalt**  
**Contents**  
**Contenu**

**Inhoud**  
**Contenido**  
**Conteúdo**

Ro-botica Global S.L.  
c/ Hercegovina 22, Bajos  
08006 Barcelona (Spain)  
Tel: +34 934 143 581  
email: info@ro-botica.com  
http://ro-botica.com



Einzelteilübersicht / Spare parts list / Liste des pièces détachées / Onderdelenoverzicht / Lista da piezas / Resumo de peça individual /  
Singoli componenti / Отдельные детали / 零件概览 ..... 2

Montagetipps / Tips for assembly / Tuyaux pour le montage / Montagetips / Consejos para el montaje / "Dicas" para montagem /  
Consigli per il montaggio / Советы по сборке / 装配建议 ..... 3

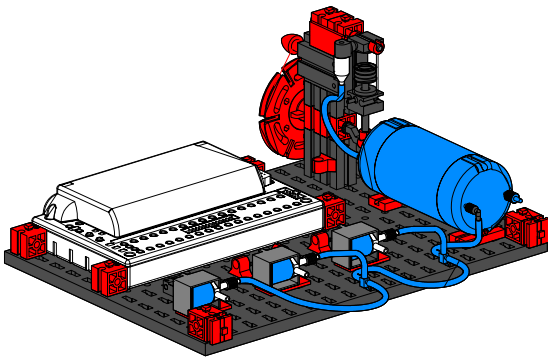

Steuereinheit / Control Unit / Unitè de commande / Besturingsunit / Unidad da mando /  
Unidade de controle / Centralina / Блок управления / 控制单元 ..... 4

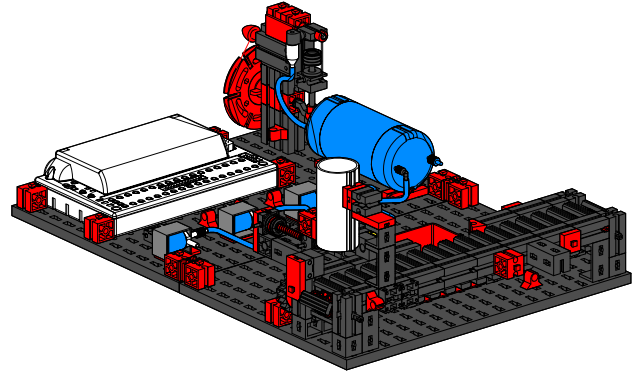

Förderband mit Stapelmagazin / Conveyor Belt with Stacking Magazine / Convoyeur à  
bande avec magasin d'empilage / Transportband met stapelmagazijn / Cinta transportadora  
con almacén de apilado / Esteira de transporte com magazine de empilhamento / Nastro  
convogliatore con magazzino d'impilaggio / Транспортер со штабельным  
накопителем / 帶有堆垛庫的傳送帶 ..... 8

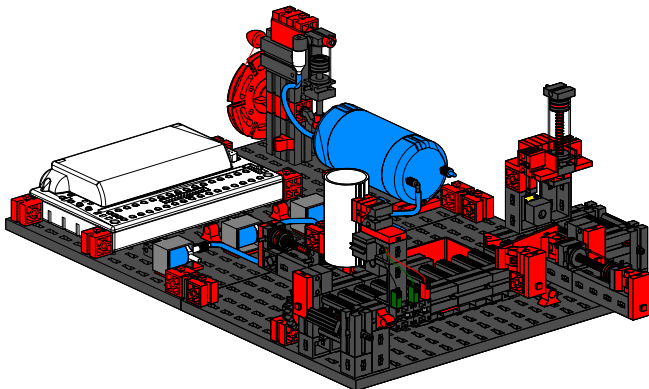

Bearbeitungsstation mit Schlechteilausstoß / Machining Station with Defective Part Ejection /  
Poste d'usinage avec rejet des pièces de rebut / Bewerkingsstation met uitstoot van slechte  
onderdelen / Estación de procesamiento con expulsión de piezas defectuosas / Estação de  
processamento com ejeção de peças de rejeito / Postazione del lavorazione con espulsione  
scarti / Обрабатывающий центр с отсортировкой бракованных  
деталей / 帶有次品剔除功能的加工站 ..... 15

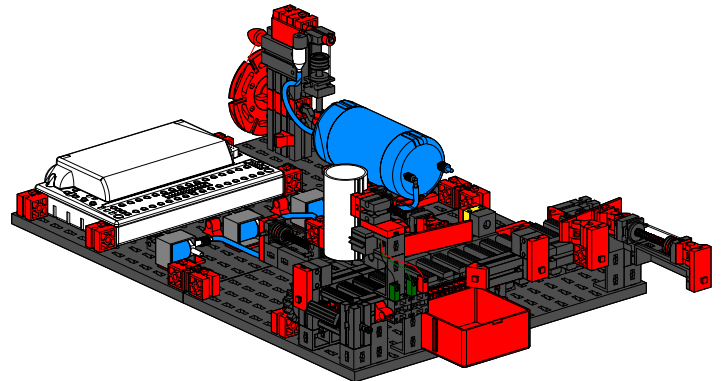

Sortieranlage / Sorting System / Trieuse / Sorteerinstallatie / Instalación de clasificación /  
Equipamento de triagem / Banco di assortimento / Сортировочная установка /  
分类设备 ..... 19

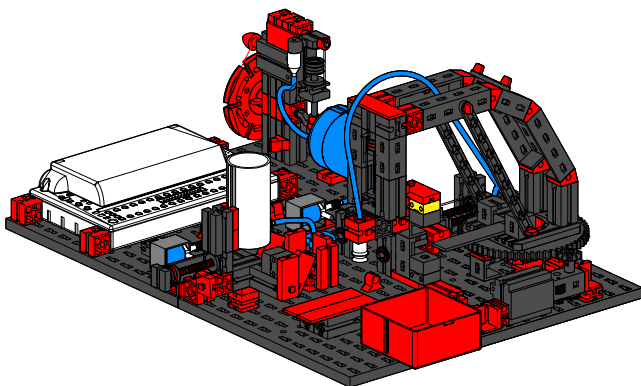

Bearbeitungsstation mit Vakuumgreifer / Machining Station with Vacuum Pickup / Poste  
d'usinage avec grappin pneumatique / Bewerkingsstation met vacuümgrijper / Estación de  
procesamiento con manipulador de vacío / Estação de processamento com agarrador de  
vácuo / Postazione del lavorazione con pinza a ventosa / Обрабатывающий центр с  
вакуумным захватом / 帶有真空抓手的加工站 ..... 27

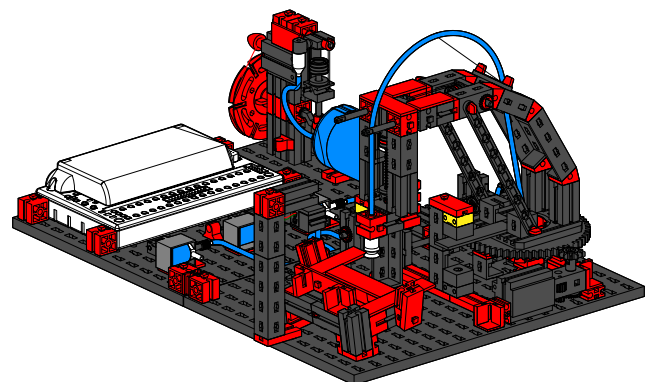











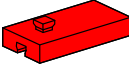
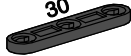
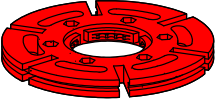
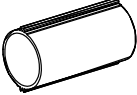



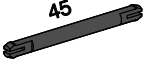



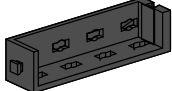



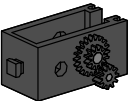

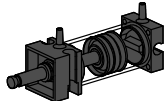



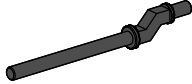



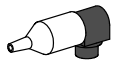

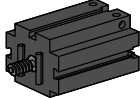

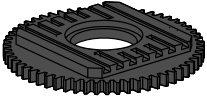

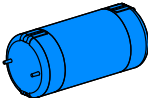

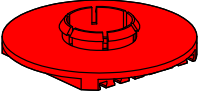
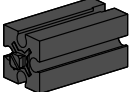



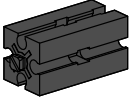



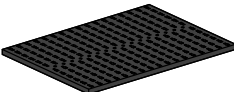
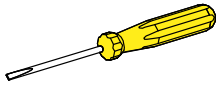

Kartengeber und -sortierer / Card Dealer and Card Sorter / Donneur de cartes et trieuse  
de cartes / Kaartgever en kaartsorteerder / Distribuidor de cartas y Clasificador de  
cartas / Distribuidor de cartas e Separador de cartas / Distributore e classificatore  
di schede / Устройство раздачи и перемешивания карт /  
分牌器 / 牌分类器 ..... 36

**Einzelteilübersicht**  
**Spare parts list**  
**Liste des pièces détachées**

**Onderdelenoverzicht**  
**Lista da piezas**  
**Resumo de peça individual**













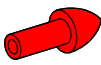

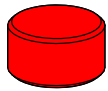
 30°	31 011 7 x		31 642 2 x		35 049 13 x		36 912 1 x
	31 019 1 x		31 663 1 x		35 063 1 x		36 915 7 x
	31 021 1 x		31 708 2 x		35 064 3 x		36 920 9 x
	31 032 1 x		31 762 36 x		35 065 3 x		36 921 4 x
	31 058 2 x		31 981 2 x		35 327 3 x		36 922 7 x
	31 078 1 x		31 982 39 x		35 328 9 x		36 937 1 x
	31 082 1 x		32 064 19 x		35 945 3 x		36 949 1 x
	31 336 27 x		32 071 2 x		35 969 8 x		36 970 1 x
	31 337 20 x		32 293 2 x		36 134 2 x		36 981 1 x
	31 390 1 x		32 321 2 x		36 190 1 x		37 003 1 x
	31 391 1 x		32 879 14 x		36 248 108 x		37 034 1 x
	31 422 1 x		32 880 4 x		36 323 6 x		37 237 7 x
	31 426 6 x		32 881 6 x		36 334 8 x		37 238 4 x
	31 436 6 x		32 985 2 x		36 443 1 x		37 468 12 x
	31 597 1 x		35 031 2 x		36 532 4 x		37 679 2 x

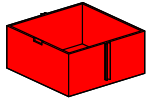
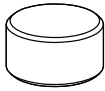

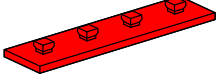
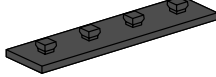
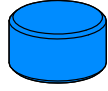
**Einzelteilübersicht**  
**Spare parts list**  
**Liste des pièces détachées**

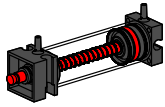
**Onderdelenoverzicht**  
**Lista da piezas**  
**Resumo de peça individual**

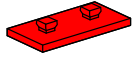

	37 681 1 x		38 242 1 x		128 599 1 x		133 200 2 x
	37 875 2 x		38 416 4 x		130 961 1 x		133 201 2 x
	38 216 5 x		38 464 5 x		133 008 1 x		133 202 2 x
	38 240 8 x		38 546 2 x		133 027 4 x		133 407 1 x
	38 241 6 x		77 312 1 x		133 028 1 x		

**Montagetipps**  
**Tips for assembly**  
**Tuyaux pour le montage**

**Montagetipps**  
**Consejos para el montaje**  
**"Dicas" para montagem**

**Consigli per il montaggio**  
**Советы по сборке**  
**装配建议**

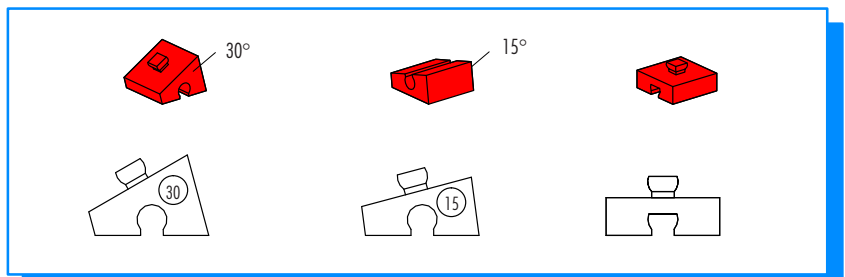
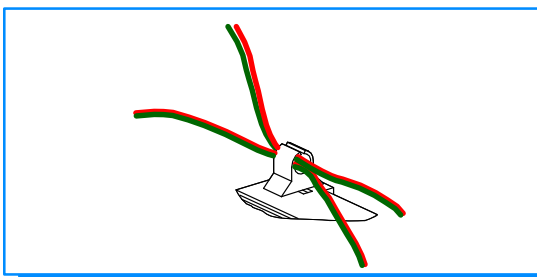
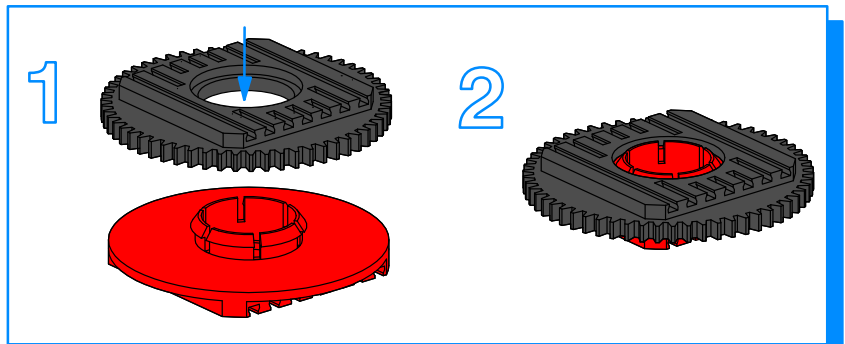
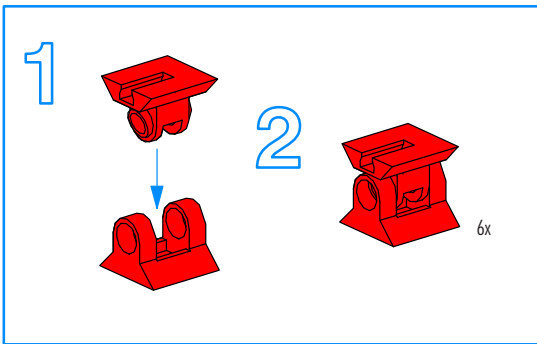

- Alle Einzelteile, insbesondere bewegliche Teile sind falls notwendig zu warten und zu reinigen.
- All components, especially moving parts, should be maintained and cleaned as necessary.
- Toutes les pièces détachées et en particulier les pièces mobiles, sont, si nécessaire, à entretenir et à nettoyer.
- Alle onderdelen, vooral de bewegende delen, kunnen, indien noodzakelijk, onderhouden en gereinigd worden.

- Achtung  
Verletzungsgefahr an Bauteilen mit funktionsbedingten scharfen Kanten und Spitzen!
- Caution  
Be careful not to hurt yourself on components with sharp or pointed edges!
- Attention  
Risque de blessure sur les éléments comportant des arêtes et o pointes vives indispensables au bon fonctionnement!
- Let op  
U kunt zich bezeren aan bouwstenen met scherpe randen of punten!

- Es necesario limpiar y mantener en buen estado todas las diferentes piezas - especialmente las piezas móviles.
- Caso necessário, todas as peças individuais, especialmente peças móveis, tem que ser submetidas à manutenção e ser limpadas.
- Se necessario, tutti i singoli componenti, soprattutto le parti mobili, si devono eventualmente sottoporre a manutenzione e pulizia.
- Все детали, особенно подвижные, требуют ухода и чистки.
- 必要时应保养和清洁所有零件, 尤指运动部件。

- Attenzione  
Esiste il pericolo di lesione con i pezzi di costruzione che hanno bordi e punte spigolosi necessari per la funzionalità del pezzo!
- Atenção  
Perigo de ferimentos em peças componentes com cantos vivos e pontas obrigatórias para o funcionamento !
- Attention  
Pericolo di lesioni dovute a componenti con spigoli vivi e punte per motivi funzionali!
- Будьте осторожны  
Об острые края деталей и и наконечники можно обрезать!
- 注意  
因功能需要而带有锋利的棱边和尖角的部件可能会带来受伤危险!